



FUSAMATIC™
FLEXTEE TAPPING TEE
FOR GAS AND WATER



FUSAMATIC™

FLEXTREE TAPPING TEE

FOR GAS AND WATER



Fusion Group Limited pioneers of polyethylene pipe jointing in the UK and across the globe.

Fusion designs and manufactures electrofusion fittings, creates polyethylene fabrications, and distributes electrofusion boxes, automatic butt fusion machines and tooling. Fusion also offers an extensive range of spigot fittings. Our products are used in a multitude of applications worldwide, from gas and water infrastructure, to mining, energy and agricultural projects. Our people are valued for their knowledge and experience of polyethylene and their passion to deliver innovation.

Fusion became a member of the AVK Group of Companies in 2017. A partnership that has resulted in a broader product and service offer and strengthened our manufacturing base.

The Fusamatic Flextee is designed to provide a solution to the jointing of tapping tees to oval and coiled pipe, enabling secure and robust quality joints every time.

Sizes

Sizes range from d63 – 180mm with 20, 25 and 32mm outlets.

Pressure ratings

All Flextee tapping tees are manufactured in virgin PE100 black polyethylene and pressure rated up to 16 bar for water applications and 10 bar for gas applications.

Specifications

All Flextee tapping tees are tested and have 3rd party approval against the following standards;

- EN 12201-3
- EN 1555-3

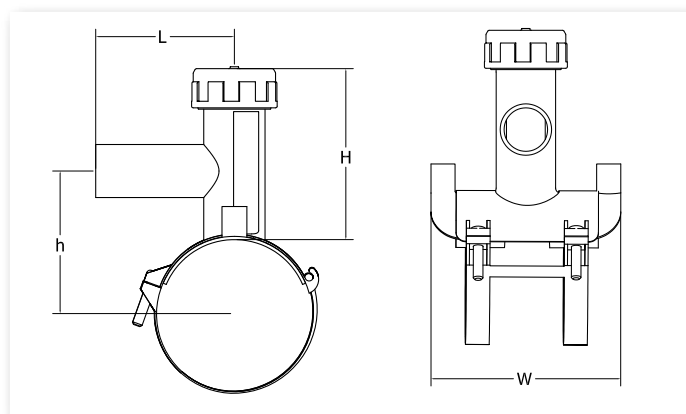

4mm Pin Fitting Code	4.7mm Pin Fitting Code	Fitting Size	L	H	h	W	Fusion Time	Cooling Time	Weight	Box Quantity	Box Size (W X L X D)
		mm	mm	mm	mm	mm	secs	mins	Kg		mm
FLTBKHF63X20U	FLTBKHA63X20U	63 x 20	83	100	59.5	119	110	10	0.22	10	295 X 485 X 199
FLTBKHF63X25U	FLTBKHA63X25U	63 x 25	83	100	59.5	119	110	10	0.22	10	295 X 485 X 199
FLTBKHF63X32U	FLTBKHA63X32U	63 x 32	83	100	59.5	119	110	10	0.22	10	295 X 485 X 199
FLTBKHF75X20U	FLTBKHA75X20U	75 x 20	83	100	65.5	119	110	10	0.22	10	295 X 485 X 199
FLTBKHF75X25U	FLTBKHA75X25U	75 x 25	83	100	65.5	119	110	10	0.22	10	295 X 485 X 199
FLTBKHF75X32U	FLTBKHA75X32U	75 x 32	83	100	65.5	119	110	10	0.22	10	295 X 485 X 199
FLTBKHF90X20U	FLTBKHA90X20U	90 x 20	83	100	73	119	110	10	0.22	10	295 X 485 X 199
FLTBKHF90X25U	FLTBKHA90X25U	90 x 25	83	100	73	119	110	10	0.22	10	295 X 485 X 199
FLTBKHF90X32U	FLTBKHA90X32U	90 x 32	83	100	73	119	110	10	0.22	10	295 X 485 X 199
FLTBKHF110X20U	FLTBKHA110X20U	110 x 20	93	100	83	119	120	10	0.22	10	295 X 485 X 199
FLTBKHF110X25U	FLTBKHA110X25U	110 x 25	93	100	83	119	120	10	0.22	10	295 X 485 X 199
FLTBKHF110X32U	FLTBKHA110X32U	110 x 32	93	100	83	119	120	10	0.22	10	295 X 485 X 199
FLTBKHF125X20U	FLTBKHA125X20U	125 x 20	93	100	90.5	119	120	10	0.23	10	295 X 485 X 199
FLTBKHF125X25U	FLTBKHA125X25U	125 x 25	93	100	90.5	119	120	10	0.23	10	295 X 485 X 199
FLTBKHF125X32U	FLTBKHA125X32U	125 x 32	93	100	90.5	119	120	10	0.23	10	295 X 485 X 199
FLTBKHF160X20U	FLTBKHA160X20U	160 x 20	93	100	108	119	140	10	0.24	5	295 X 485 X 199
FLTBKHF160X25U	FLTBKHA160X25U	160 x 25	93	100	108	119	140	10	0.24	5	295 X 485 X 199
FLTBKHF160X32U	FLTBKHA160X32U	160 x 32	93	100	108	119	140	10	0.24	5	295 X 485 X 199
FLTBKHF180X20U	FLTBKHA180X20U	180 x 20	93	100	118	119	140	10	0.24	5	295 X 485 X 199
FLTBKHF180X25U	FLTBKHA180X25U	180 x 25	93	100	118	119	140	10	0.24	5	295 X 485 X 199
FLTBKHF180X32U	FLTBKHA180X32U	180 x 32	93	100	118	119	140	10	0.24	5	295 X 485 X 199

FUSAMATIC™ FLEXTREE TAPPING TEE

FEATURES AND BENEFITS



Barcode / QR Code

Quality control is central to the success of Fusion's fittings. The unique barcode configuration, including QR code provides full traceability of raw material for each individual fitting and welding information when used in conjunction with electrofusion boxes equipped with a barcode scanner.



Indicator

Pressure, created by the expanding molten plastic in the jointing area (inside the fitting) during the electrofusion process, will force out the indicator lug. This is a visible sign that the necessary jointing pressure has been achieved.

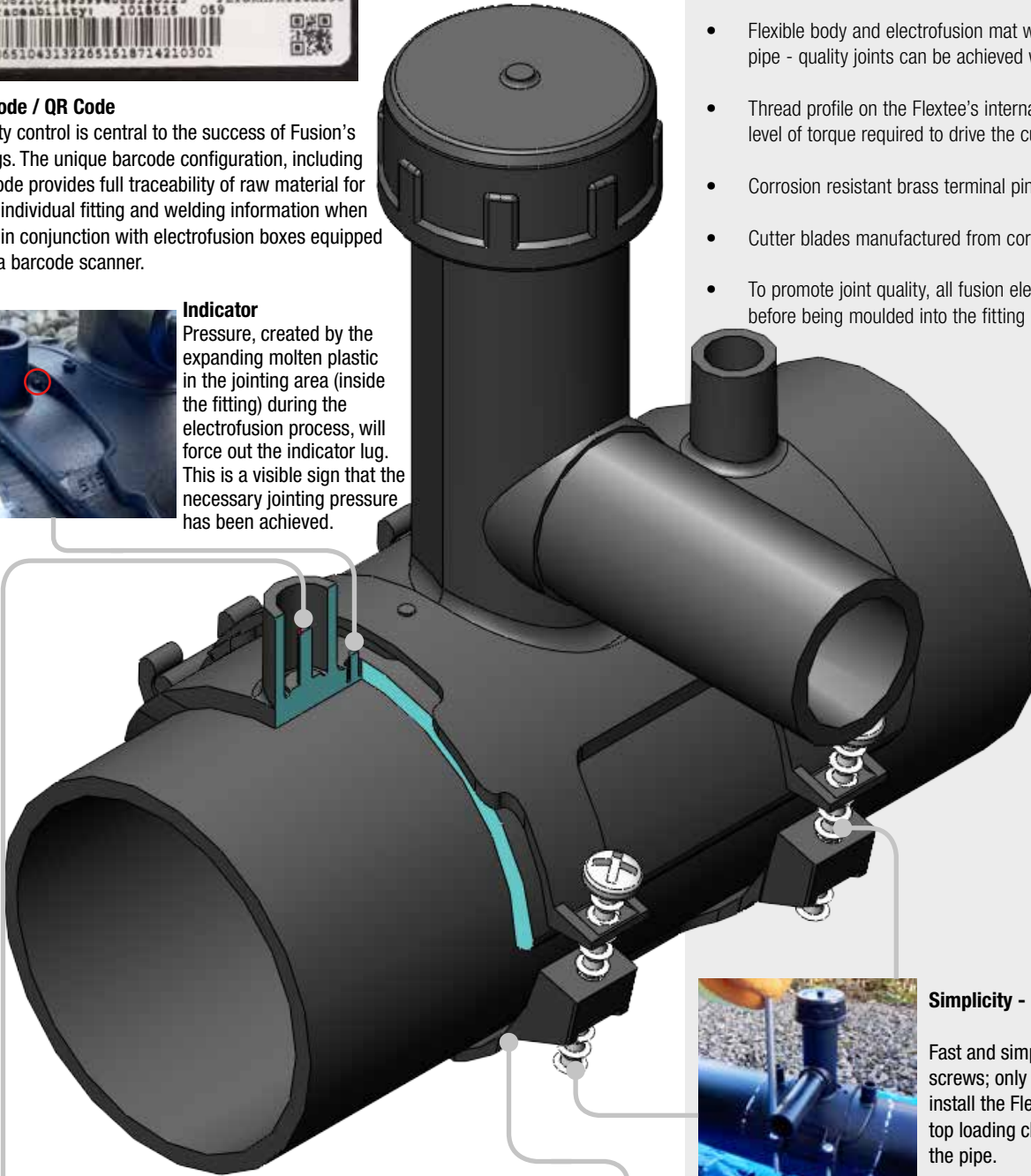

- Designed to provide a solution to the jointing of tapping tees to oval and coiled pipe - enabling secure and robust quality joints everytime.
- Flexible body and electrofusion mat which conforms to the shape of the pipe - quality joints can be achieved without re-rounding clamps.
- Thread profile on the Flextee's internal cutting mechanism reduces the level of torque required to drive the cutter through the body of the main.
- Corrosion resistant brass terminal pins.
- Cutter blades manufactured from corrosion resistant stainless steel.
- To promote joint quality, all fusion elements are coated with enamel before being moulded into the fitting body.

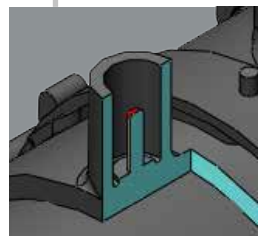

Fusamatic Pin

Invented by Fusion, the Fusamatic pin provides a totally automatic method for ensuring the correct welding parameters are used. Within each Fusamatic pin is a resistor. When the electrofusion box is connected to the fitting, the Fusamatic pin enables it to automatically identify the correct fusion time required to make the joint. All the operator has to do is press go!



Simplicity - Installation

Fast and simple installation by means of two screws; only a screwdriver is required to install the Flextee - removes the need for a top loading clamp which can further deform the pipe.



Simplicity - Understrap

Sacrificial understrap keeps the tapping tee in place both during and after the electrofusion jointing process, thereby reducing installation time and error.

THE GOOD GUIDE TO ELECTROFUSION JOINTING



ELECTROFUSION DO'S

- Use a shelter and ground sheet in wet or dry conditions.
- Always use equipment that has been regularly maintained and calibrated.
- Ensure control box voltage is compatible with fitting.
- Always use alignment/restraining clamps where necessary.
- Cut pipe ends square for electrofusion sockets.
- Scrape pipe and/or spigot surfaces fully.
- Keep scraped pipe and/or spigot surfaces and fittings clean.
- Ensure correct fusion and cooling times are adhered to.
- Assemble joint and fuse immediately after scraping pipe.
- Carry out quality checks before cutting through pipe.
- Mark the fused fitting with the joint number for traceability.

ELECTROFUSION DONT'S

- Do not start the joining process unless it can be completed in one go.
- Do not leave fittings out of protective bags.
- Do not use dirty fittings.
- Do not touch prepared pipe surfaces or fusion areas.
- Do not allow assemblies to get damp prior to joining.
- Do not touch fusion indicators during the welding cycle.
- Do not remove joint from clamps until the full cooling time has elapsed.
- Do not remove integral cutter from the saddle once the main has been drilled.
- Do not use control box in a trench with gaseous atmosphere.
- Never fuse a fitting for a second time.
- Failed joints should not be used. Cut out failed joint and fuse another fitting to the required specification on distance from failed fitting.
- Electrofusion joints should not be carried out on slotted or drilled pipe sections, only solid walled pipe sections.

DISCLAIMER
THE DATA PROVIDED IN THIS DOCUMENT IS NOT BINDING AND MAY BE SUBJECT TO MODIFICATIONS.

THIS DOCUMENT IS SUPPLIED AS A GUIDANCE ONLY. THE WELDING OPERATOR IS RESPONSIBLE FOR ENSURING ALL WORK IS PERFORMED EXCLUSIVELY BY TRAINED AND COMPETENT PERSONNEL AND IN COMPLIANCE WITH BOTH NATIONAL AND INTERNATIONAL RULES AND GUIDELINES FOR ELECTROFUSION INSTALLATION.

SAFETY NOTES

Although we make every effort in the design of our products to ensure operator safety, please remember the following precautions:

- Never allow molten or semi-molten polyethylene to come into contact with the skin. If this happens, flush the affected area with cold water and seek expert medical advice.

DO NOT UNDER ANY CIRCUMSTANCE ATTEMPT TO PULL THE MATERIAL FROM THE SKIN AS THIS COULD REMOVE THE SKIN

- Do not attempt to lift long lengths of pipe without assistance or mechanical aid.
- Normal precautions should be observed when handling electrical equipment although, for safety reasons, all 110v portable generator sets should be "Centre Tapped" for site use +55/0/-55 volts.
- To afford protection during jointing, always wear protective workwear such as gloves, safety glasses and safety boots.
- Ensure that equipment is serviced on a regular basis as recommended by the equipment manufacturer.

ADDITIONAL INFORMATION

STANDARD DIMENSION RATIO (SDR)

The SDR is calculated by dividing the minimum (nominal) outside diameter (OD) by the minimum wall thickness (WT) i.e.

SDR =	OD	125	
	WT	11.4	= 11

From 25mm PE pipe and above the ratio between the outside diameter and the wall thickness remains constant for specific pressure ratings of the pipe.

TRANSITION FROM PE PIPE TO OTHER PIPE AND FITTINGS

Various transition fittings are available to connect to metallic valves, hydrants and pipework. One common method is the use of PE flanges.

It is important to follow manufacturers' recommendations for tightening the necessary bolts. Bolt torque details are supplied with the flanges. It is also important to support any equipment independently of all PE pipework (ie. valves to be mounted on concrete blocks).

This guide will provide basic information to enable the operative to:

- Understand the principles of electrofusion joining.
- Carry out pre-joining equipment checks.
- Identify pipe and compatible fittings.
- Inspect for, and identify acceptable quality joints.
- Make satisfactory electrofusion joints from compatible pipes and fittings.
- Site the equipment.

Safety Notice

To ensure operator safety and comply with Health and Safety regulations all electrofusion control boxes must be operated from an effectively earthed supply in accordance with the manufacturers' operating instructions.

Equipment required:



Generator of suitable size to power control box - refer to manufacturers' literature for power requirements



Welding tent/shelter and ground sheet



Indelible marker pen



Electrofusion control box with appropriate leads



Pipe cutter



Scraping equipment



Screwdriver



Test cap

Principles

Electrofusion is a method of joining PE pipes using fittings with integral heating elements. Socket fittings are used to join mains and service pipes; and saddle fittings are used to connect services to mains.

The term "socket" covers couplers, elbows, reducers etc. The term "saddle" covers branch saddles and tapping tees.

The pipe to be joined must be prepared by removing the outer surface layer to a depth of around 0.2mm, pipe and fitting are then clamped together to prevent movement. A voltage is applied across the fitting terminals via a control box.

An electric current is passed through the wire which heats the wire and melts the polymer, fusing the fitting to the pipe. After welding, the joint is allowed to cool before removing the restraining clamps.

Pipe/Fitting Selection

Check that both pipe(s) and fitting to be joined are compatible, **only compatible materials should be joined together.** Check PN and SDR rating marked on fitting and compare with that of the pipe. If in doubt, seek advice from the pipe or fitting manufacturer.

Fusamatic fittings are suitable for jointing in ambient temperatures between -10°C and +40°C and do not require any form of pre-heat or temperature compensation. For jointing outside these temperatures guidance should be sought from the manufacturer.

Siting Equipment

Wherever possible, the electrofusion equipment should be placed on a suitable clean, dry base board or ground sheet inside a tent/shelter to minimise contamination.



Ensure that the area where the weld is to be carried out has any surface water removed and that some form of groundsheet is used to isolate the jointing area from the trench floor.

THE GOOD GUIDE TO ELECTROFUSION SADDLE JOINTING

ADDITIONAL EQUIPMENT REQUIRED:

- 12mm cutter key (min length 150mm) and drive
- Phillips / Pozi screwdriver

SADDLE JOINT ASSEMBLY PREPARATION

1. Expose pipe to which saddle is to be welded ensuring the pipe has no inclusions or gouges in the area where the fitting is to be fused.
2. Ensure enough clearance has been provided (in a trench environment) to carry out the installation.
3. Remove loose dirt from the pipe using a prescribed wipe, damp cloth or paper towel and ensure any risk of contamination from trench wall is minimized.
4. With the fitting still in its protective bag, place over required position on pipe. Mark pipe surface 10mm clear all around contact area and cross hatch the area using a marker pen.

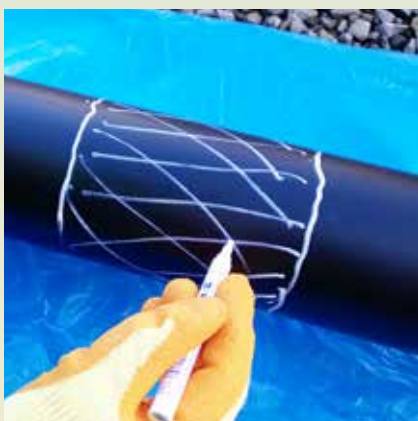

5. Scrape the marked area, ensuring that each stroke of the scraper overlaps the preceding one, keeping hand clear of the scraped surface at all times.



6. For skinned pipe use the manufacturers' recommended tools to remove the skin. Some skinned pipe still requires a scraping operation seek advice from the pipe manufacturer prior to commencement of the installation.
7. Immediately after pipe preparation remove fitting from bag and attach to pipe using the sacrificial understrap, clip in place.



8. Tighten the two retaining screws until the stops meet.



Important Note: Do not touch either prepared pipe surface or the electrofusion surface of the saddle.

Making the weld

1. Check generator has sufficient fuel.
2. Start the generator and plug the control box input lead into the generator output socket. Connect the control box output leads to the fitting terminals - if automatic fittings and control box are being used, connect the red lead to the fitting terminal with the red pin, connect the black lead to the plain pin.



3. Check that the weld time marked on the fitting is displayed on the control box display. For manual fittings, check the weld time marked on the fitting and enter this figure into the control box. For 'barcode' fittings weld parameters are selected by scanning the barcode with the barcode scanner.
4. Respond to prompts from the box. Press 'START' and hold down until display begins countdown. The weld cycle is complete when the timer reaches zero and the control box 'CYCLE FINISH' indicator shows.
5. Allow weld to cool for the full time stated on the fitting.

Quality Checks

- Check for any error messages on the control box
- Check fusion indicator has risen on the fitting (saddle fittings only usually have one indicator).
- Check for signs of melt exudation around the saddle base.
- Check that the fitting is square to the main.

SADDLE OUTLET JOINT ASSEMBLY PREPARATION

1. Check pipe ends are cut square and are free from surface damage and swarf.

2. Wipe loose dirt from the area of outlet to be clamped and fused with a prescribed wipe, damp cloth or paper towel (wipe any contaminants from inside of the outlet).

3. Mark the insertion depth on the pipe by holding the bagged fitting against the pipe.

4. Cross hatch the area to be scraped plus an additional 20-50mm using the indelible marker pen.

5. Scrape outlet of tapping tee using an appropriate mechanical scraper, for the length of the insertion depth plus 10-20mm. Ensure the whole surface area has been scraped.



6. Open fitting bag, check the fitting is clean and immediately place over outlet and push up to centre stops, or for fittings without centre stops insert the pipe to half the overall fitting length (mark this distance on the pipe prior to insertion). Leave bag over fittings for temporary protection.

7. Prepare the service pipe in the same way as the outlet, as previously described.

8. Remove the bag and push the service pipe into the fitting. Mark the penetration depth on the pipe and tighten the restraining clamp.



9. Check fitting penetration - using previously marked lines on pipe. Visually check alignment. Rotate the fitting to ensure no excessive forces are present.

10. Proceed with the weld as detailed previously.

11. Carry out quality checks as detailed below.

QUALITY CHECKS

- Check for any error messages on the control box
- Check fusion indicators have risen on both sides of the fitting.
- Check for signs of melt exudation from the ends of the fitting.
- Check that the pipe has not moved by looking at the insertion depth marks.

PRESSURE TESTING OF JOINT

- Once the tapping tee has been fused to the pipe and connected to the service pipe, a pressure test can be carried out using a test cap in accordance with the appropriate industry guidelines.
- It is recommended that a pressure no greater than 1.5x the working pressure be used to test the joint integrity.

FAILURE OF PRESSURE TEST AND QUALITY CHECK

If the weld fails any of the above checks then:

- a) for sockets - cut out the joint and replace.
- b) for saddles - do not tap the main and cut off the stack so it cannot be used. Carry out a repeat weld using a new fitting at least one pipe diameter away from the failed joint (this may differ depending on utility requirements).

CUTTING THROUGH MAIN

1. Unscrew cap and insert cutter key into integral cutter.

2. Turn the cutter key clockwise until the cutter has cut through the main.



3. Retract cutter until top is flush with stack and refit cap.



*** Note: a small amount of leakage will occur until the cutter is fully retracted.**



Fusion Group Limited

Chesterfield
Derbyshire
S41 9PZ
England, UK

T: +44 (0) 1246 268666
E: sales@fusiongroup.com
www.fusiongroup.com

